

Removal and Installation of Left or Right Front Rubber Mounting of Engine Suspension

The right front and the right rear rubber mountings are identical and the same applies to the left front and rear rubber mountings. In order to avoid any confusion between the right and the left side, the rubber mountings are marked with a directional arrow and the inscription "vorne" ("front") (see Fig. 22 — 1/1).

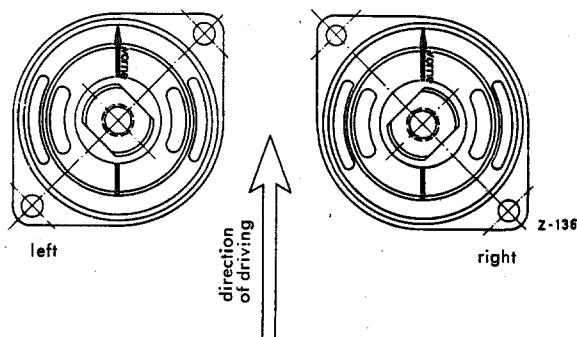

Fig. 22 — 1/1

1. Open the hood and unscrew the hexagon screw (1) from the rubber mounting (3).

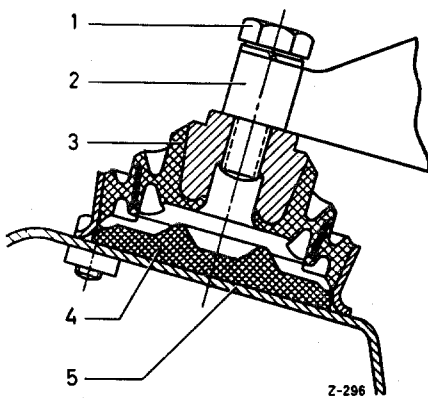

Fig. 22 — 1/2

- | | |
|-------------------|------------------------------|
| 1 Hexagon screw | 4 Buffer plate 121 223 00 65 |
| 2 Engine support | 5 Front axle support |
| 3 Rubber mounting | |

When doing this, hold the rubber mounting steady with an SW 22 wrench (see Fig. 22 — 1/2).

2. Unscrew the two hexagon screws by which the rubber mounting is fixed to the front axle support.
3. Use a jack to lift the engine so that the rubber mounting can be taken out together with the buffer plate.
Place a suitable pad between jack and oil pan.

Installation:

4. Fit a new rubber mounting with buffer plate (4) between engine support (2) and front axle support (5) (see Fig. 22 — 1/2).

Note: Care should be taken to ensure that the directional arrow with the inscription "vorne" ("front") points in the direction of travel (see Fig. 22 — 1/1).

5. Fix the rubber mounting to the front axle support, using the two hexagon screws with spring washers.
6. Insert the hexagon screw (1) with spring washer through the engine support and screw finger-tight into the rubber mounting. Let down jack and tighten up the hexagon screw (1) firmly, holding the rubber mounting steady during this operation with an SW 22 wrench.